



Miniature Vibration Transducer NTIP12



Parameter	Unit	NTIP12
Axial sensitivity ($\pm 20\%$).....	pC/g	0.02
Relative transverse sensitivity.....	%	< 5
Amplitude range.....	g	± 70000
Max. shock limit (peak value).....	g	± 100000
Operating temperature range.....	$^{\circ}\text{C}$	$-60 \cdots +200$
Variation of axial sensitivity by $^{\circ}\text{C}$	%	< 0.03
Capacity variation in the operating temperature... range	%	± 2
Frequency range (ripple ± 1 dB).....	Hz	$2 \cdots 50000$
Self-resonant frequency in attached condition....	kHz	> 70
Strain sensitivity.....	$\text{g} \cdot \text{m}/\mu\text{m}$	< 0.3
Capacitance.....	pF	$300 \cdots 400$
Insulation resistance in normal conditions.....	MOhm	> 10 000
Housing material.....	-	Stainless steel
Built-in cable length.....	m	2
Weight (without connector and cable).....	gram	2.8

General view

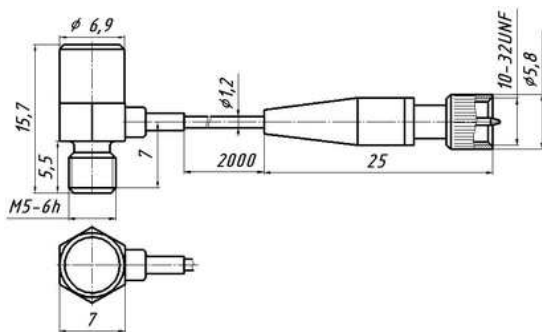

Electrical circuit

